

ZNOTES.ORG

UPDATED TO 2022 SYLLABUS

CAIE AS LEVEL  
**PHYSICS (9702)**

---

SUMMARIZED NOTES ON THE THEORY SYLLABUS

# 1. Physical quantities and units

## 1.1. Physical Quantities

- All physical quantities consist of a numerical magnitude and a unit:

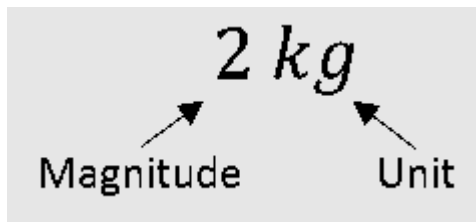

### Estimating Physical Quantities

Quantity	Estimate
Height of an adult human	2 m
Mass of an adult human	70 kg
Mass of a car	1000 kg
Power of a lightbulb	60 W
Speed of sound in air	330 ms <sup>-1</sup>
Speed of a car on the motorway	30 ms <sup>-1</sup>
Weight of an apple	1 N
Density of water	1000 kgm <sup>-3</sup>
Time taken for a sprinter to run 100m	10 s
Current in a domestic appliance	13 A
E.M.F of a car battery	12 V
Atmospheric pressure	1.0 × 10 <sup>5</sup> Pa
Young's modulus of a given material	Something × 10 <sup>11</sup>

## 1.2. SI Units

Quantity	Base Unit
Mass ( <i>m</i> )	Kilogram ( <i>kg</i> )
Length ( <i>l</i> )	Meter ( <i>m</i> )
Time ( <i>t</i> )	Second ( <i>s</i> )
Temperature ( <i>T</i> )	Kelvin ( <i>K</i> )

Quantity	Base Unit
Electric Current ( <i>I</i> )	Ampere ( <i>A</i> )

- All units (excluding those above) can be broken down to the base units
- Homogeneity can be used to prove equations.
- An equation is homogenous if base units on left hand side are the same as base units on right hand side

### Multiples

Multiple	Prefix	Symbol
10 <sup>12</sup>	Tera	( <i>T</i> )
10 <sup>9</sup>	Giga	( <i>G</i> )
10 <sup>6</sup>	Mega	( <i>M</i> )
10 <sup>3</sup>	Kilo	( <i>k</i> )

### Sub-multiples

Sub-multiple	Prefix	Symbol
10 <sup>-3</sup>	Milli	( <i>m</i> )
10 <sup>-6</sup>	Micro	( <i>μ</i> )
10 <sup>-9</sup>	Nano	( <i>n</i> )
10 <sup>-12</sup>	Pico	( <i>p</i> )

## 1.3. Systematic & Random errors

- Systematic errors:**
  - Constant error in one direction; too big or too small
  - Cannot be eliminated by repeating or averaging
  - If systematic error is small, measurement is accurate
  - Accuracy:** refers to degree of agreement between result of a measurement and true value of quantity.
- Random errors:**
  - Random fluctuations or scatter about a true value
  - Can be reduced by repeating and averaging
  - When random error is small, measurement is precise
  - Precision:** refers to degree of agreement of repeated measurements of the same quantity (regardless of whether it is close to true value or not)

### Calculations Involving Errors

For a quantity  $x = (5.0 \pm 0.2)mm$

- **Absolute uncertainty**  $\Delta x = \pm 0.2mm$
- **Fractional uncertainty**  $= \frac{\Delta x}{x} = 0.04$
- **Percentage uncertainty**  $= \frac{\Delta x}{x} \times 100\% = 4\%$
- **Combining errors:**
  - When values **added or subtracted**, add absolute error  
If  $p = \frac{2x+y}{3}$  or  $p = \frac{2x-y}{3}$ , then  $\Delta p = \frac{2\Delta x + \Delta y}{3}$
  - When values **multiplied or divided**, add % errors
  - When values are **powered** (e.g. squared), multiply percentage error with power  
If  $r = 2xy^3$ , then  $\frac{\Delta r}{r} = \frac{\Delta x}{x} + \frac{3\Delta y}{y}$

### 1.4. Scalars and Vectors

- **Scalar:** has magnitude only, cannot be -ve  
e.g. speed, energy, power, work, mass, distance
- **Vector:** has magnitude and direction, can be -ve  
e.g. displacement, acceleration, force, velocity, momentum, weight, electric field strength

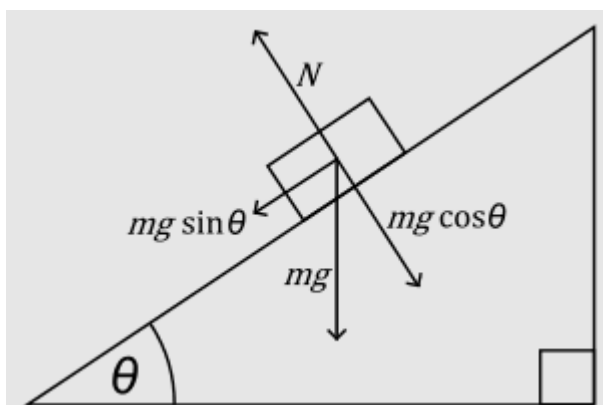

A force vector can be split into its vertical and horizontal components, which are independent on each other.

Pythagoras theorem ( $a^2 + b^2 = c^2$ ) and vector parallelograms can be used to add coplanar vectors.

## 2. # Kinematics equations

$$s = ut + \frac{1}{2}at^2$$

$$v = u + at$$

$$v^2 = u^2 + 2as$$

$$s = \frac{(v_1 + v_2)}{2} \times t$$

## Kinematics

### 2.2. Kinematics concepts

- **Distance:** total length moved irrespective of direction
- **Displacement:** distance in a certain direction
- **Speed:** distance traveled per unit time, no direction
- **Velocity:** the rate of change of displacement
- **Acceleration:** the rate of change of velocity

### 2.3. Linear Motion

- **Distance:** total length moved irrespective of direction
- **Displacement:** distance in a certain direction
- **Speed:** distance traveled per unit time, no direction
- **Velocity:** the rate of change of displacement
- **Acceleration:** the rate of change of velocity
- **Displacement-time graph:**
  - Gradient = velocity

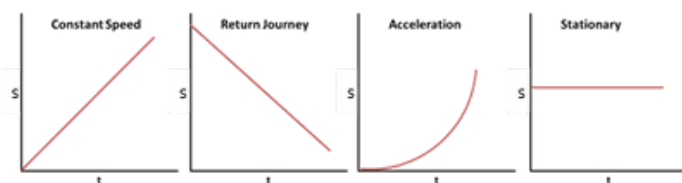

### 2.4. Non-Linear Motion

Velocity-time graph:

- Gradient = acceleration
- Area under graph = change in displacement

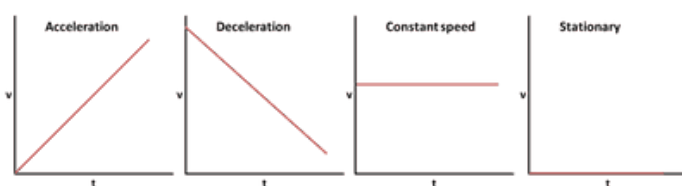

Uniform acceleration and straight-line motion equations:

$$v = u + at$$

$$s = ut + \frac{1}{2}at^2 = vt - \frac{1}{2}at^2$$

$$s = \frac{1}{2}(u + v)t \quad v^2 = u^2 + 2as$$

- Acceleration of free fall = 9.81ms<sup>-2</sup>

### 2.5. Motion of Freefalling Bodies

Displacement	Continues to curve as it accelerates	
	Graph levels off as it reaches terminal velocity	
Velocity	Continues to accelerate constantly	
	Graph curves as it decelerates and levels off to terminal velocity	
Acceleration	Straight line	
	Graph curves down to zero because the resultant force equals zero	

### 2.6. Determining Acceleration of Free Fall

- A steel ball is held on an electromagnet.
- When electromagnet switched off, ball interrupts a beam of light and a timer started.
- As ball falls, it interrupts a second beam of light & timer stopped
- Vertical distance  $h$  is plotted against  $t^2$

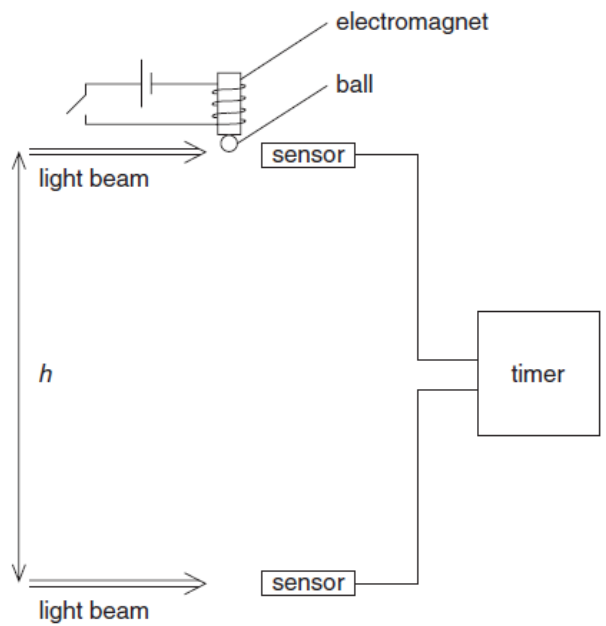

$$s = ut + \frac{1}{2}at^2 \text{ and } u = 0 ; s = \frac{1}{2}at^2 \text{ i.e } h = \frac{1}{2}gt^2$$

### 2.7. Projectile motion

- **Projectile motion:** uniform velocity in one direction and constant acceleration in perpendicular direction

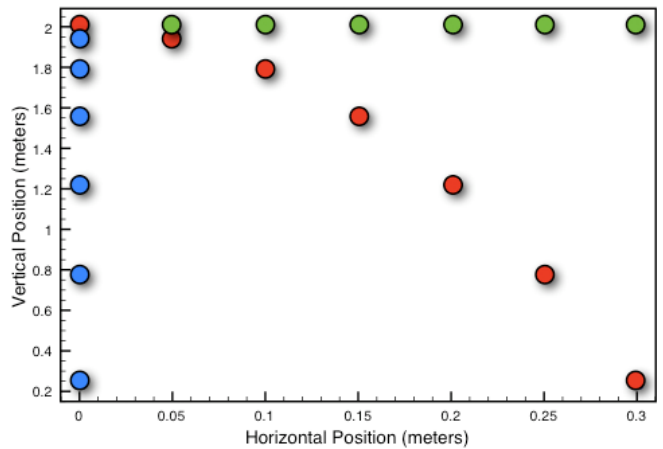

- Horizontal motion = constant velocity (speed at which projectile is thrown)
- Vertical motion = constant acceleration (cause by weight of object, constant free fall acceleration)
- Curved path - parabolic ( $y \propto x^2$ )

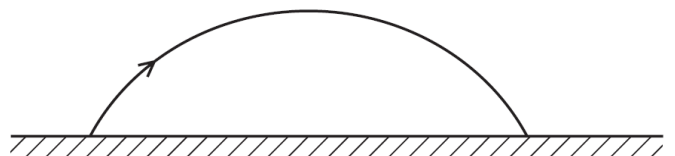

	Component of Velocity	
	Horizontal	Vertical
<b>Without air Resistance</b>	Constant	Increases at a constant rate

		<b>Component of Velocity</b>
<b>With Air resistance</b>	Decreases to zero	Increases to a constant value

### 2.8. Motion of a Skydiver

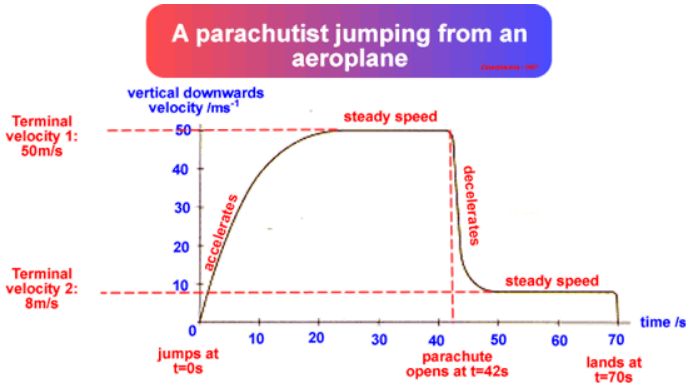

## 3. Dynamics

### 3.1. Newton's laws of motion

- First law:** if a body is at rest it remains at rest or if it is in motion it moves with a uniform velocity until it is acted on by resultant force or torque
- Second law:** the rate of change of momentum of a body is proportional to the resultant force and occurs in the direction of force;  $F = ma$
- Third law:** if a body  $A$  exerts a force on a body  $B$ , then body  $B$  exerts an equal but opposite force on body  $A$ , forming an action-reaction pair

### 3.2. Momentum

- Linear momentum:** product of mass and velocity

$$p = mv$$

- Force:** rate of change of momentum

$$F = \frac{mv - mu}{t}$$

- Principle of conservation of linear momentum:** when bodies in a system interact, total momentum remains constant provided no external force acts on the system.

$$m_A u_A + m_B u_B = m_A v_A + m_B v_B$$

### 3.3. Mass and Weight

Mass	Weight
Measured in kilograms	Measured in Newtons
Scalar quantity	Vector quantity
Constant throughout the universe	Not constant
	$W = mg$

- Mass:** is a measure of the amount of matter in a body, & is the property of a body which resists change in motion.
- Weight:** is the force of gravitational attraction (exerted by the Earth) on a body.

### 3.4. Elastic Collisions

- Total **momentum** conserved
- Total **kinetic energy** is conserved

**Example:** Two identical spheres collide elastically. Initially,  $X$  is moving with speed  $v$  and  $Y$  is stationary. What happens after the collision?

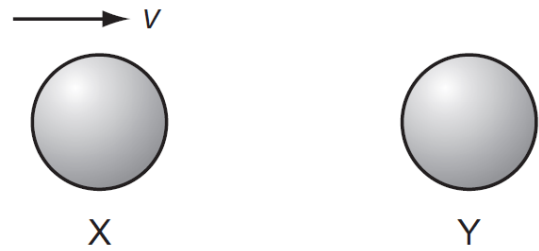

$X$  stops and  $Y$  moves with speed  $v$ :

(relative velocity before collision) - (relative velocity after collisions)

$$u_A - u_B = v_B - v_A$$

### 3.5. Inelastic Collisions

relative speed of approach  $>$  relative speed of separation

- Total momentum is conserved
- Perfectly inelastic collision:** only momentum is conserved, and the particles stick together after collision (i.e. move with the same velocity)
- In inelastic collisions, total energy is conserved but  $E_k$  may be converted into other forms of energy e.g. heat

### 3.6. Collisions in Two Dimensions

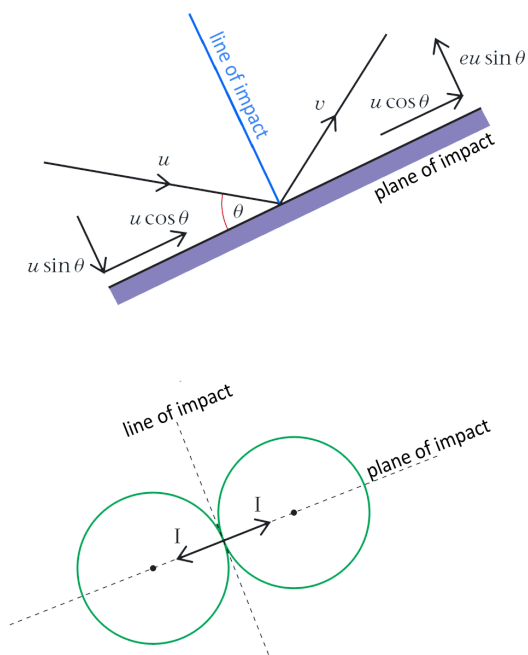

- Change in momentum (impulse) affecting each sphere acts along line of impact
- Law of conservation of momentum applies along line of impact
- Components of velocities of spheres along plane of impact unchanged

## 4. Forces, Density, Pressure

- **Force:** rate of change of momentum
- **Density:** mass per unit of volume of a substance
- **Pressure:** force per unit area
- **Finding resultant (nose to tail):**
  - By accurate scale drawing
  - Using trigonometry

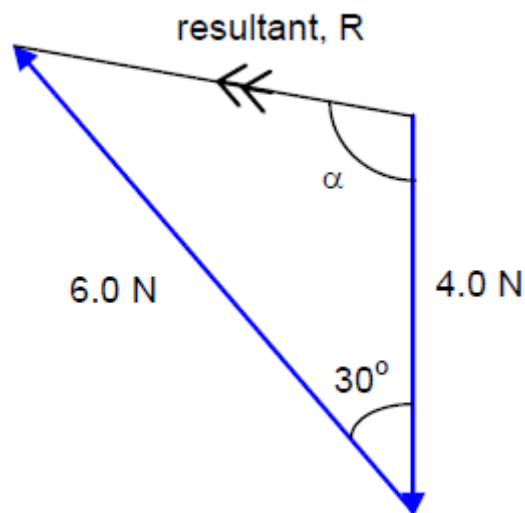
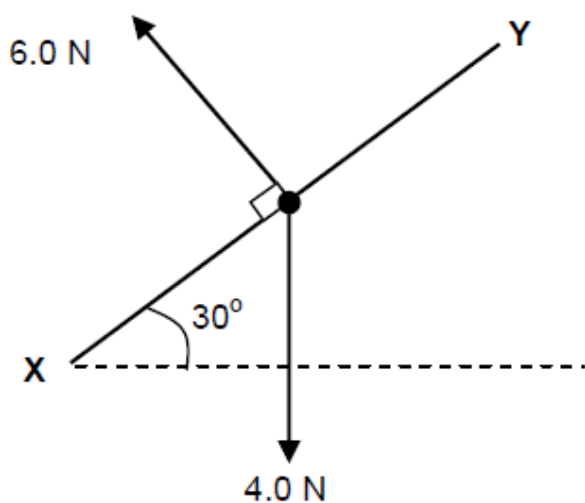

- **Forces on masses in gravitational fields:** a region of space in which a mass experiences an (attractive) force due to the presence of another mass.
- **Forces on charge in electric fields:** a region of space where a charge experiences an (attractive or repulsive) force due to the presence of another charge.
- **Upthrust:** an upward force exerted by a fluid on a submerged or floating object
- **Origin of Upthrust:**  
Pressure on Bottom Surface > Pressure on Top Surface  
∴ Force on Bottom Surface > Force on Top Surface  
⇒ Resultant force upwards
- **Frictional force:** force that arises when two surfaces rub
  - Always opposes relative or attempted motion
  - Always acts along a surface
  - Value varies up to a maximum value
- **Viscous forces:**
  - A force that opposes the motion of an object in a fluid;
  - Only exists when there is motion.
  - Its magnitude increases with the speed of the object
- **Centre of gravity:** point through which the entire weight of the object may be considered to act
- **Couple:** a pair of forces which produce rotation only
- **To form a couple:**
  - Equal in magnitude
  - Parallel but in opposite directions
  - Separated by a distance  $d$
- **Moment of a Force:** product of the force and the perpendicular distance of its line of action to the pivot

$$\text{Moment} = \text{Force} \times \perp \text{Distance from Pivot}$$

- **Torque of a Couple:** the product of one of the forces of the couple and the perpendicular distance between the lines of action of the forces.

$$\text{Torque} = \text{Force} \times \perp \text{Distance between Forces}$$

- **Conditions for Equilibrium:**
  - Resultant force acting on it in any direction equals zero
  - Resultant torque about any point is zero.
- **Principle of Moments:** for a body to be in equilibrium, the sum of all the anticlockwise moments about any point must be equal to the sum of all the clockwise moments about that same point.

## 4.2. Pressure in Fluids

- Fluids refer to both liquids and gases
- Particles are free to move and have  $E_K$   $\therefore$  they collide with each other and the container. This exerts a small force over a small area causing pressure to form.

## Derivation of Pressure in Fluids

Volume of water =  $A \times h$

Mass of Water == *density*  $\times$  *volume* =  $\rho \times A \times h$

Weight of Water == *mass*  $\times$  *g* =  $\rho \times A \times h \times g$

Pressure =  $\frac{\text{Force}}{\text{Area}} = \text{AreaForce} = \frac{\rho \times A \times h \times g}{A}$

Pressure =  $\rho gh$

## 5. Work, Energy, Power

- **Law of conservation of energy:** the total energy of an isolated system cannot change—it is conserved over time. Energy can be neither created nor destroyed, but can change form e.g. from g.p.e to k.e

### 5.2. Work Done

- **Work done by a force:** the product of the force and displacement in the direction of the force  
 $W = Fs$
- **Work done by an expanding gas:** the product of the pressure and the change in volume of gas

$$W = P \cdot \delta V$$

- **Condition for formula:** temperature of gas is constant
- The change in distance of the piston,  $\delta x$ , is very small therefore it is assumed that  $P$  remains constant

### 5.3. Gravitational, Elastic and Electric Potential Energy

- **Gravitational Potential Energy:** arises in a system of masses where there are attractive gravitational forces between them. The g.p.e of an object is the energy it possesses by virtue of its position in a gravitational field.

- **Elastic potential energy:** this arises in a system of atoms where there are either attractive or repulsive short-range inter-atomic forces between them.
- **Electric potential energy:** arises in a system of charges where there are either attractive or repulsive electric forces between them.

### 5.4. Deriving Gravitational Potential Energy

$$W = Fs \text{ \& } w = mg = F$$

$$\therefore W = mgs$$

$s$  in direction of force =  $h$  above ground

$$\therefore W = mgh$$

### 5.5. Deriving Kinetic Energy

$$W = Fs \text{ \& } F = ma$$

$$\therefore W = mas$$

$$v^2 = u^2 + 2as \implies as = \frac{1}{2}(v^2 - u^2)$$

$$\therefore W = m \cdot \frac{1}{2}(v^2 - u^2)$$

$$\therefore W = \frac{1}{2}mv^2$$

### 5.6. Internal Energy

- **Internal energy:** sum of the K.E. of molecules due to its random motion & the P.E. of the molecules due to the intermolecular forces.
- **Gases:**  $k.e. > p.e$ 
  - Molecules far apart and in continuous motion =  $k.e$
  - Weak intermolecular forces so very little  $p.e$ .
- **Liquids:**  $k.e. \approx p.e$ .
  - Molecules able to slide to past each other =  $k.e$ .
  - Intermolecular force present and keep shape =  $p.e$ .
- **Solids:**  $k.e. < p.e$ .
  - Molecules can only vibrate  $\therefore k.e$  very little
  - Strong intermolecular forces  $p.e$  high

### 5.7. Power and Efficiency

- **Power:** work done per unit of time

$$\text{Power} = \frac{\text{Work Done}}{\text{Time Taken}}$$

- Deriving it to form  $P = fv$

$$P = \frac{W.d}{T} \text{ \& } W.d. = Fs$$

$$\therefore P = \frac{Fs}{T} = F \left( \frac{s}{t} \right)$$

$$\therefore P = Fv$$

- **Efficiency:** ratio of (useful) output energy of a machine to the input energy

$$\text{Efficiency} = \frac{\text{Useful Energy Output}}{\text{Total Energy Input}} \times 100$$

## 6. Deformation of Solids

### 6.1. Compressive and Tensile Forces

- Deformation is caused by a force
- Tensile force
  - Act away from each other, object stretched out

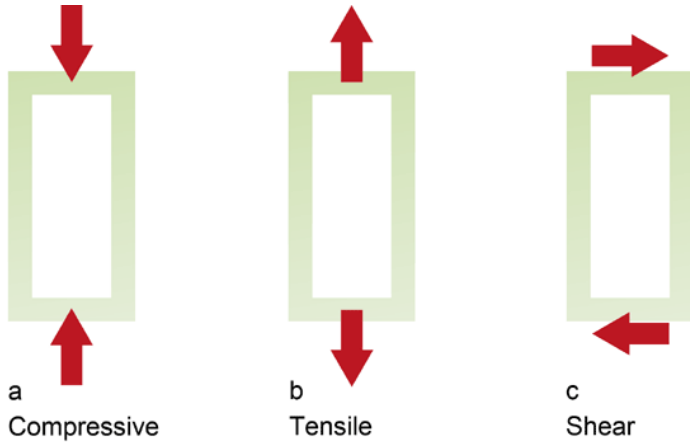

- Compressive force
  - Act towards each other, object squashed

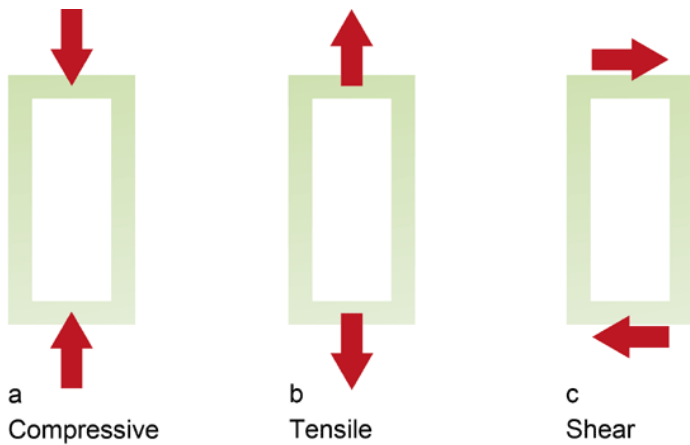

### 6.2. Hooke's Law

- A spring produces an extension when a load is attached
- According to Hooke's law, the extension produced is proportional to the applied force (due to the load) as long as the elastic limit is not exceeded.

$$F = ke$$

Where  $k$  is the spring constant; force per unit extension

- Calculating effective spring constants:

Series	Parallel
$\frac{1}{k_E} = \frac{1}{k_1} + \frac{1}{k_2}$	$k_E = k_1 + k_2$

### 6.3. Determining Young's Modulus

Measure diameter of wire using micrometer screw gauge  
Set up arrangement as diagram:

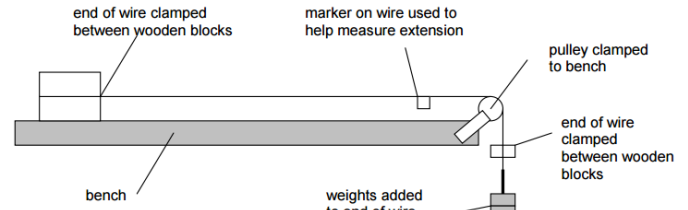

Attach weights to end of wire and measure extension

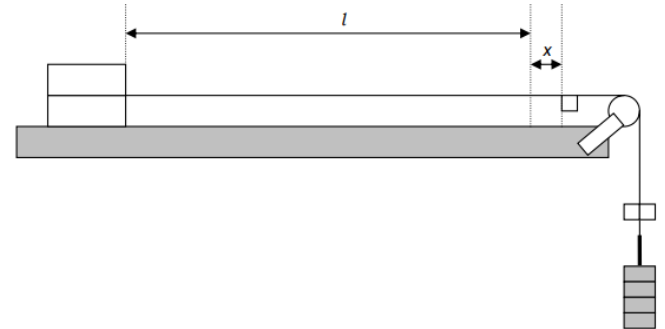

Calculate Young's Modulus using formula

### 6.4. Stress, Strain and Young's Modulus

- **Stress:** force applied per unit cross-sectional area

$$\sigma = \frac{F}{A} \text{ in Nm}^{-2} \text{ or Pascals}$$

- **Strain:** fractional increase in original length of wire

$$\epsilon = \frac{e}{l} \text{ no units}$$

- **Young's Modulus:** ratio of stress to strain

$$E = \frac{\sigma}{\epsilon} \text{ in Nm}^{-2} \text{ or Pascals}$$

- **Stress-Strain Graph:**

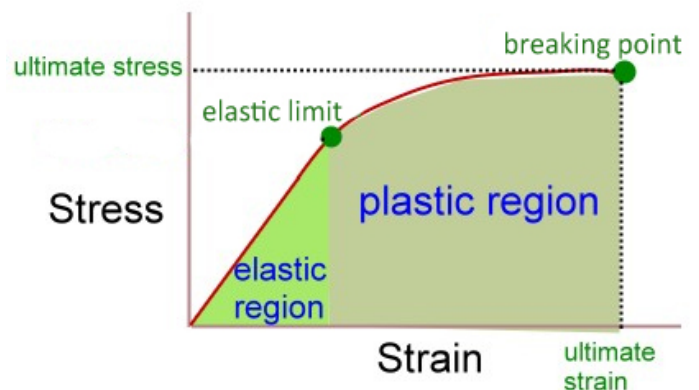

Gradient = Young's modulus

- **Elastic deformation:** when deforming forces removed, spring returns back to original length
- **Plastic deformation:** when deforming forces removed, spring does not return back to original length



- **Strain energy:** the potential energy stored in or work done by an object when it is deformed elastically
- Strain energy = area under force-extension graph

$$W = \frac{1}{2}k\Delta L^2$$

## 7. Waves

- **Displacement:** distance of a point from its undisturbed position
- **Amplitude:** maximum displacement of particle from undisturbed position
- **Period:** time taken for one complete oscillation
- **Frequency:** number of oscillations per unit time

$$f = \frac{1}{T}$$

- **Wavelength:** distance from any point on the wave to the next exactly similar point (e.g. crest to crest)
- **Wave speed:** speed at which the waveform travels in the direction of the propagation of the wave
- **Progressive waves** transfer energy from one position to another

### 7.2. Deducing Wave Equation

$$Speed = \frac{Distance}{Time}$$

- Distance of 1 wavelength is  $\lambda$  and time taken for this is  $T$

$$\therefore v = \frac{\lambda}{T} = \lambda \left(\frac{1}{T}\right)$$

$$f = \frac{1}{T} \text{ so } v = f\lambda$$

### 7.3. Phase Difference

- Phase difference between two waves is the difference in terms of fraction of a cycle or in terms of angles (A B)
- Wave A leads wave B by  $\theta$  or Wave B lags wave A by  $\theta$

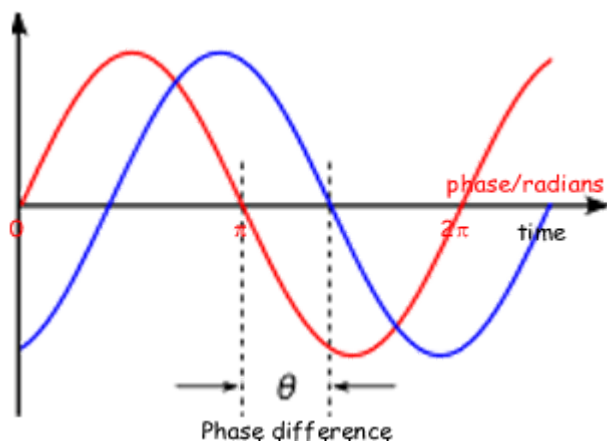

### 7.4. Intensity

- Rate of energy transmitted per unit area perpendicular to direction of wave propagation.

$$Intensity = \frac{Power}{Cross\ Sectional\ Area}$$

$$Intensity \propto Amplitude^2$$

## 7.5. Transverse and Longitudinal waves

- Transverse Waves
- Oscillation of wave particles perpendicular to direction of propagation
- Polarization can occur
- E.g. light waves

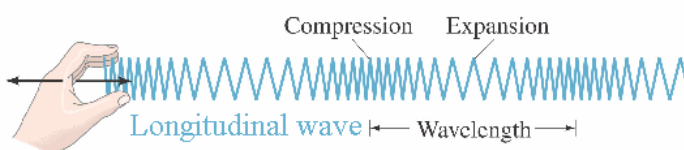
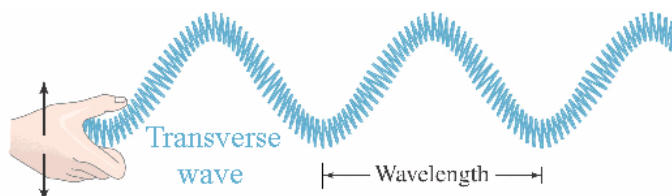

Copyright © 2005 Pearson Prentice Hall, Inc.

- Longitudinal Waves
  - Oscillations of wave particle parallel to direction of propagation
  - Polarization cannot occur
  - E.g. sound waves

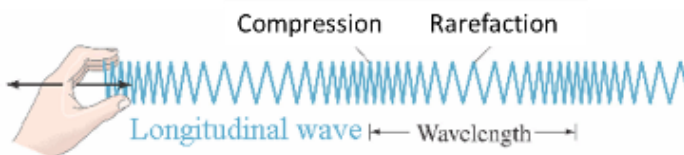

- **Polarization:** vibration of particles is confined in one direction in the plane normal to direction of propagation

### Light Passing Through Crossed Polarizers

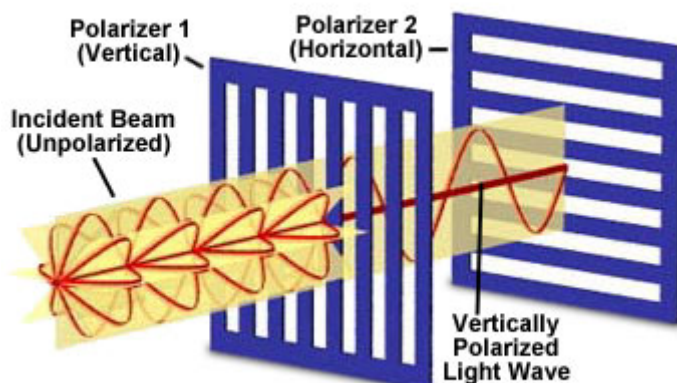
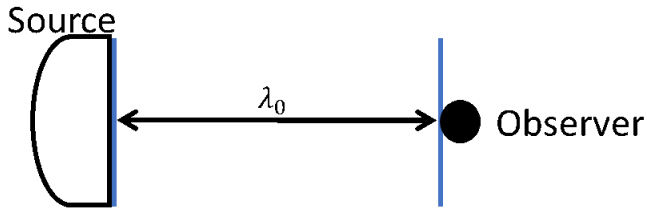

Figure 1

## 7.6. The Doppler Effect

- Arises when source of waves moves relative to observer
- Can occur in all types of waves, including sound & light

- Source stationary relative to Observer:



- Source moving towards Observer:

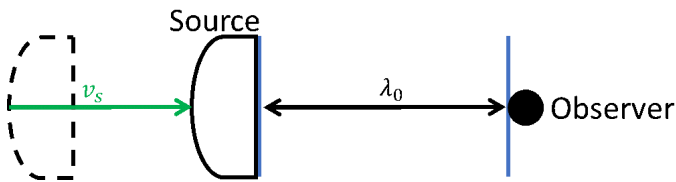

- Source moving away from Observer:

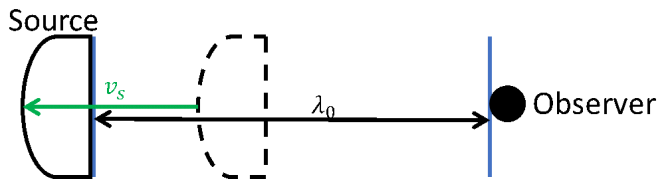

- Change in wavelength leads to change in frequency
- Observed frequency ( $f_0$ ) is different from actual frequency ( $f_s$ ); related by equation:

$$f_0 = \frac{f_s v}{v \pm v_s}$$

where  $v$  is speed of wave &  $v_s$  is speed of source relative to observer

## 7.7. Electromagnetic Waves

- As electromagnetic wave progresses, wavelength **decreases** and frequency **increases**

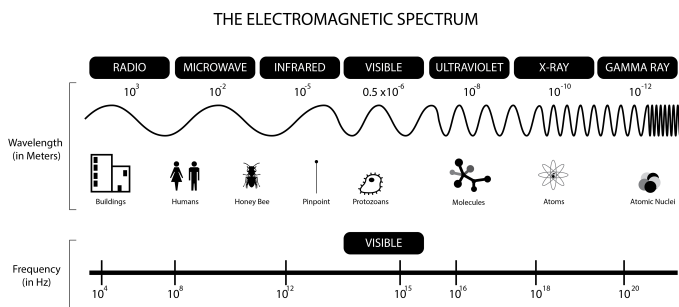

All electromagnetic waves:

- All travel at the speed of light:  $3 \times 10^8 \text{ m s}^{-1}$
- Travel in free space (don't need medium)
- Can transfer energy
- Are transverse waves

## 8. Superposition

### 8.1. Principle of Superposition

- When two or more waves of the same type meet at a point, the resultant displacement is the algebraic sum of the individual displacements

### 8.2. Interference and Coherence

- **Interference:** the formation of points of cancellation and reinforcement where 2 coherent waves pass each other
- **Coherence:** waves having a constant phase difference
- **Constructive**
  - Phase difference = even  $\frac{\lambda}{2}$
  - Path difference = even  $\frac{\lambda}{2}$

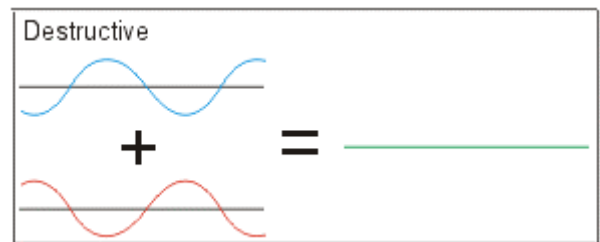
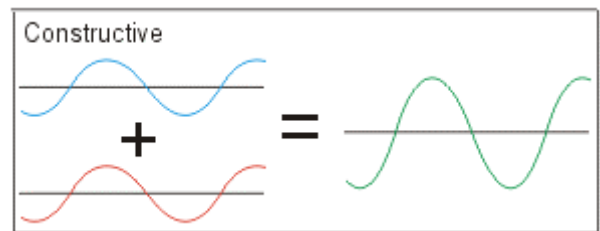

- **Destructive**
  - Phase difference = odd  $\frac{\lambda}{2}$
  - Path difference = odd  $\frac{\lambda}{2}$

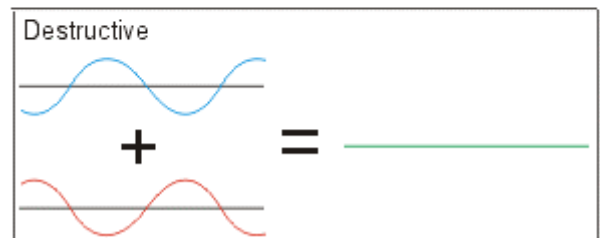
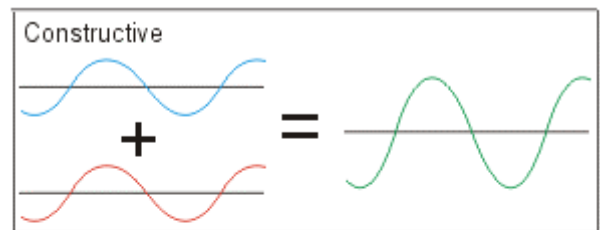

### 8.3. Two-Source Interference

## Two-Point Source Interference Pattern

- = Maximum Pressure
- = Minimum Pressure

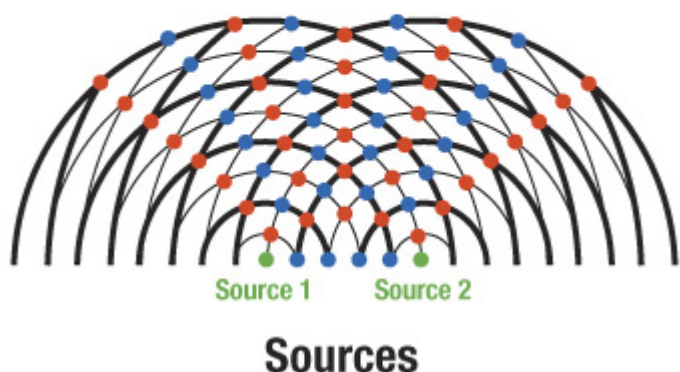

- **Conditions for Two-Source Interference:**
  - Meet at a point
  - Must be of the same type
  - Must have the same plane of polarization
- **Demonstrating Two-Source Interference:**

Water	Ripple generators in a tank
Light	Double slit interference
Microwaves	Two microwave emitters

## 8.4. Formation of Stationary waves

- A stationary wave is formed when two progressive waves of the same frequency, amplitude and speed, travelling in opposite directions are superposed.
- **Node:** region of destructive superposition where waves always meet out of phase by  $\pi$ ,  $\therefore$  displacement = zero
- **Antinode:** region of constructive superposition where waves meet in phase  $\therefore$  particle vibrate with max amp

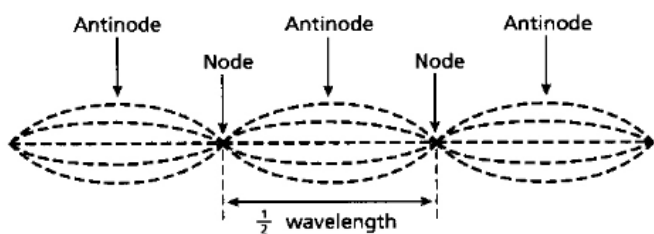

- Neighboring nodes & antinodes separated by  $\frac{1}{2}\lambda$
- Between 2 adjacent nodes, particles move in phase and they are out of phase with the next two nodes by  $\pi$

Stationary wave at different times:

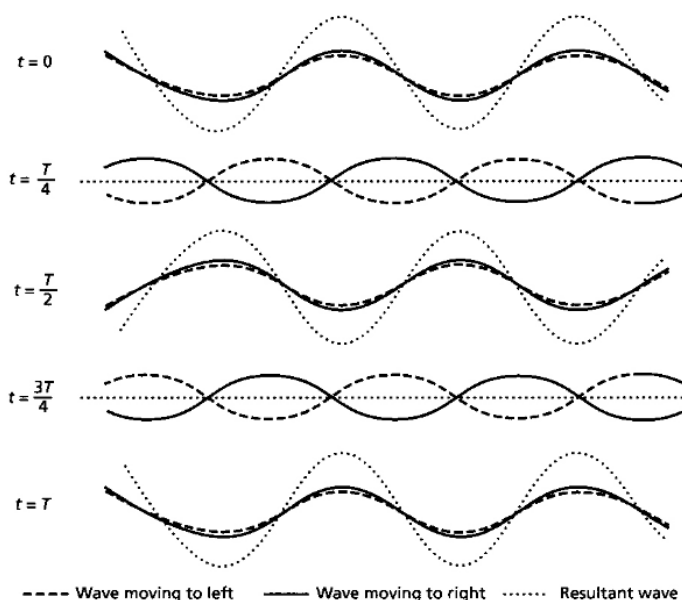

## 8.5. Stationary Wave Experiments

**Stretched String:**

- String either attached to wall or attached to weight
- Stationary waves will be produced by the direct and reflected waves in the string.

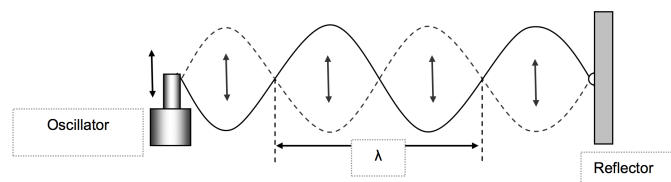

**Microwaves:**

- A microwave emitter placed a distance away from a metal plate that reflects the emitted wave.
- By moving a detector along the path of the wave, the nodes and antinodes could be detected.

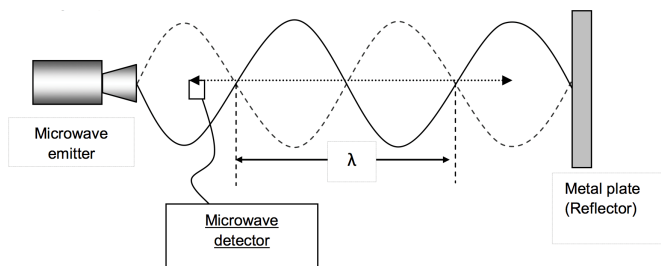

**Air Columns:**

- A tuning fork held at the mouth of an open tube projects a sound wave into the column of air in the tube.
- The length can be changed by varying the water level.
- At **certain** lengths tube, the air column resonates
- This is due to the formation of stationary waves by the incident and reflected sound waves at the water surface.
- **Node always formed at surface of water**

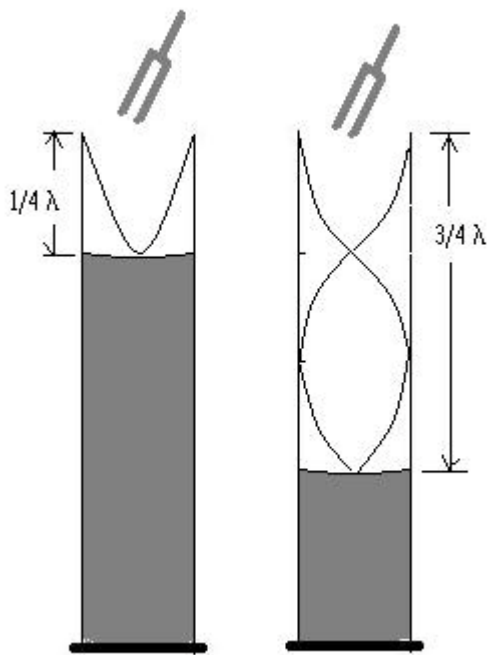

### 8.6. Stationary and Progressive Waves

Stationary Waves	Progressive Waves
Stores energy	Transmits energy
Have nodes & antinodes	No nodes & antinodes
Amplitude increases from node to antinode	Amplitude constant along length of the wave
Phase change of $\pi$ at node	No phase change

### 8.7. Diffraction

- **Diffraction:** the spreading of waves as they pass through a narrow slit or near an obstacle
- For diffraction to occur, the size of the gap should be equal to the wavelength of the wave.

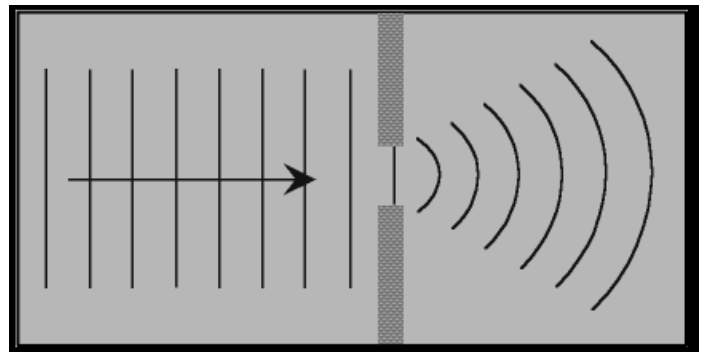
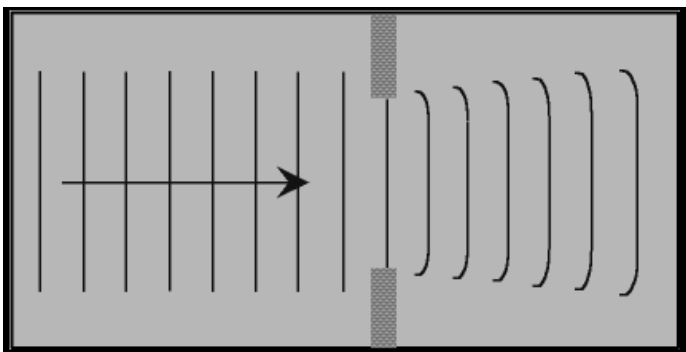

### 8.8. Double-Slit Interference

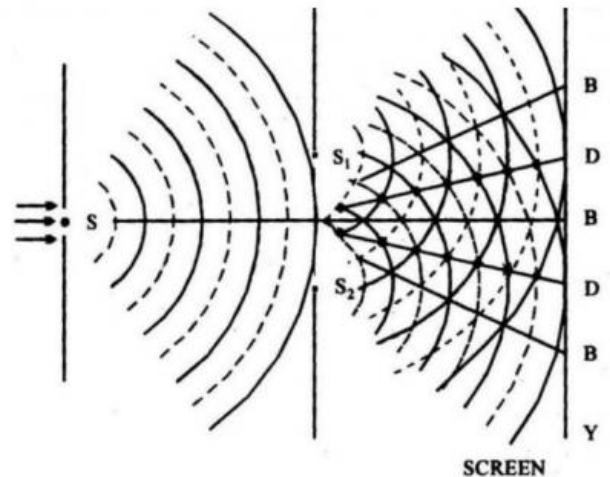

$$\lambda = \frac{ax}{D}$$

Where  $a$  = slit separation

$D$  = distance from slit to screen

$x$  = fringe width

### 8.9. Diffraction Grating

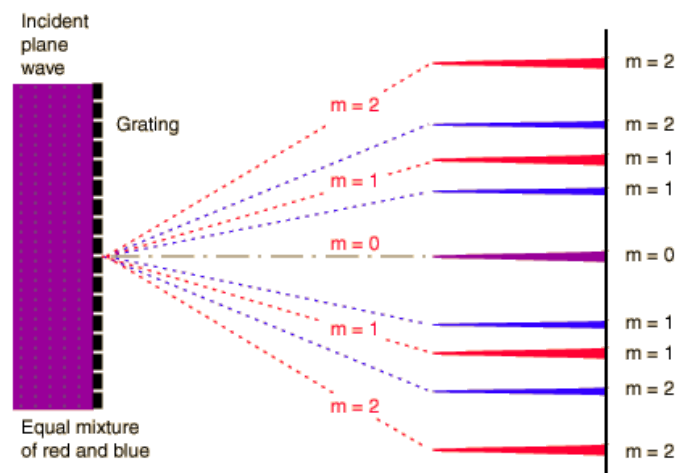

$$d \sin \theta = n\lambda$$

Where  $d$  = distance between successive slits

$=$  reciprocal of number of lines per meter

$\theta$  = angle from horizontal equilibrium

$n$  = order number

$\lambda$  = wavelength

Comparing to double-slit to diffraction grating:

- Maxima are sharper compared to fringes
- Maxima very bright; more slits, more light through

## 9. Electricity

- **Electric current:** flow of charged particles
- **Charge** at a point. product of the current at that point and the time for which the current flows,

$$Q = It$$

- **Coulomb:** charge flowing per second pass a point at which the current is one ampere
- **Charge is quantized:** values of charge are not continuous they are discrete
- All charges are multiples of charge of  $1e$ :  $1.6 \times 10^{-19}C$
- **Potential Difference:** two points are a potential difference of 1V if the work required to move 1C of charge between them is 1 joule
- **Volt:** joule per coulomb

$$W = VQ$$

$$P = VI; P = I^2R; P = \frac{V^2}{R}$$

### 9.2. Current-Carrying Conductors

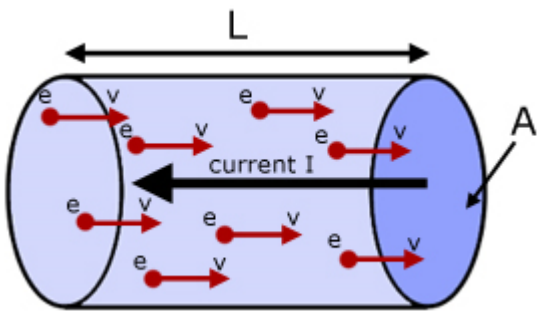

- Electrons move in a certain direction when p.d. is applied across a conductor causing current
- **Deriving a formula for current:**

$$I = \frac{Q}{t}$$

vol. of container = $LA$	$t = \frac{L}{v}$
No. of free electrons = $nLA$	
Total charge = $Q = nLAq$	

$$\therefore I = \frac{nLAq}{\frac{L}{v}}$$

$$I = Anvq$$

Where  $L$  = length of conductor

$A$  = cross-sectional area of conductor

$n$  = no. free electrons per unit volume

$q$  = charge on 1 electron

$v$  = average electron drift velocity

### 9.3. Current-P.D. Relationships

- Metallic Conductor
  - Ohmic conductor
  - $V/I$  constant

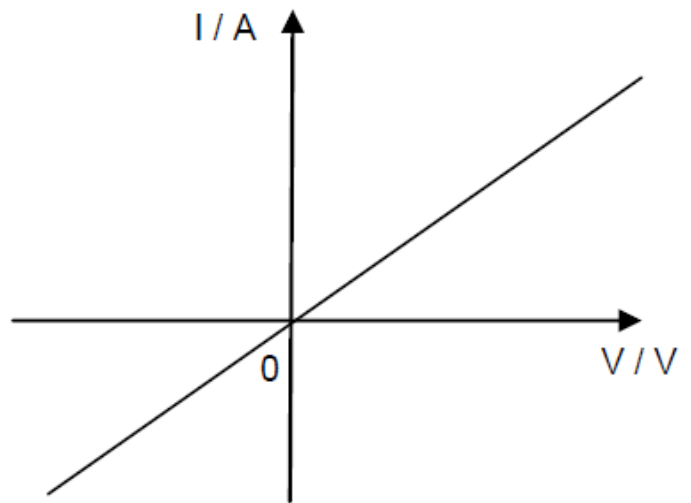

- Filament Lamp
  - Non-ohmic conductor
  - Volt  $\uparrow$
  - Temp.  $\uparrow$
  - Vibration of ions  $\uparrow$
  - Collision of ions with  $e^-$   $\uparrow$
  - Resistance  $\uparrow$

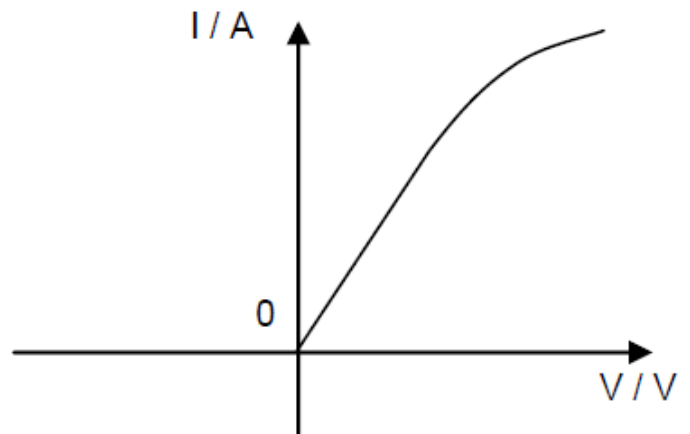

- Thermistor
  - Non-ohmic conductor
  - Volt  $\uparrow$
  - Temp.  $\uparrow$
  - Released  $e^-$   $\uparrow$
  - Resistance  $\downarrow$

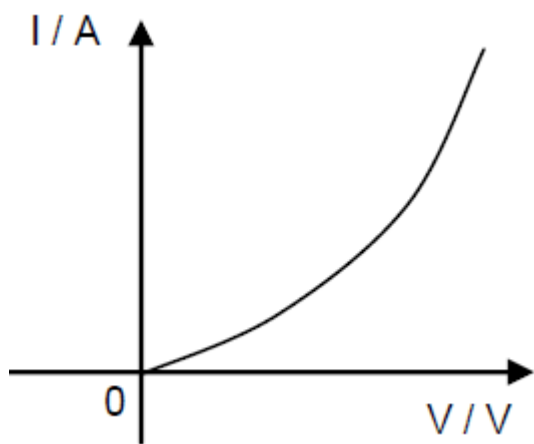

- Semi-Conductor Diode
  - Non-ohmic conductor
  - Low resistance in one direction and infinite resistance in opposite

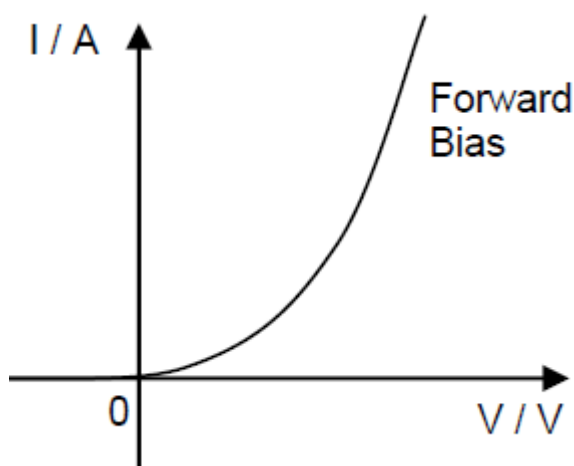

- **Ohm's law:** the current in a component is proportional to the potential difference across it provided physical conditions (e.g. temp) stay constant.

## 10. D.C. Circuits

- **Electromotive Force:** the energy converted into electrical energy when 1C of charge passes through the power source

### 10.2. Potential Difference and Electromotive Force

- Potential difference (work done per unit charge)
  - energy transformed **from electrical to other** forms per unit charge
- Electromotive force (work done per unit charge)
  - energy transformed **from other forms to electrical**

### 10.3. Internal Resistance

**Internal Resistance:** resistance to current flow within the power source; reduces p.d. when delivering current

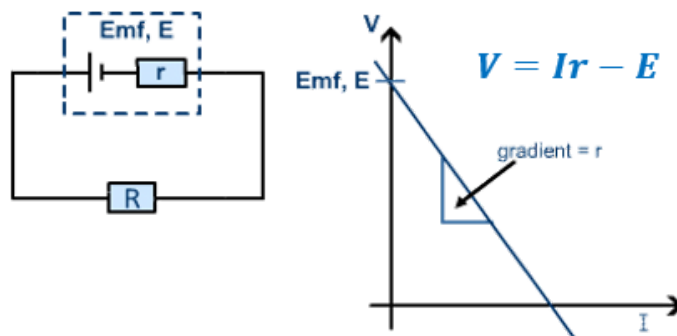

Voltage across resistor:  $V = IR$

Voltage lost to internal resistance:  $V = Ir$

Thus e.m.f.:  $E = IR + Ir$

$$E = I(R + r)$$

### 10.4. Kirchhoff's 1st Law

*Sum of currents into a junction*

IS EQUAL TO

*Sum of currents out of junction.*

- Kirchhoff's 1st law is another statement of the law of conservation of charge

### 10.5. Kirchhoff's 2nd Law

*Sum of e.m.f.s in a closed circuit*

IS EQUAL TO

*Sum of potential differences*

- Kirchhoff's 2nd law is another statement of the law of conservation of energy

### 10.6. Deriving Effective Resistance in Series

From Kirchhoff's 2nd Law:

$$E = \sum IR$$

$$IR = IR_1 + IR_2$$

Current constant therefore cancel:

$$R = R_1 + R_2 \quad \wedge n$$

### 10.7. Deriving Effective Resistance in Parallel

From Kirchhoff's 1st Law:

$$I = \sum I$$

$$I = I_1 + I_2$$

$$\frac{V}{R} = \frac{V}{R_1} + \frac{V}{R_2}$$

Voltage constant therefore cancel:

$$\frac{1}{R} = \frac{1}{R_1} + \frac{1}{R_2} \quad \wedge n$$

### 10.8. Potential Divider

- A potential divider divides the voltage into smaller parts.

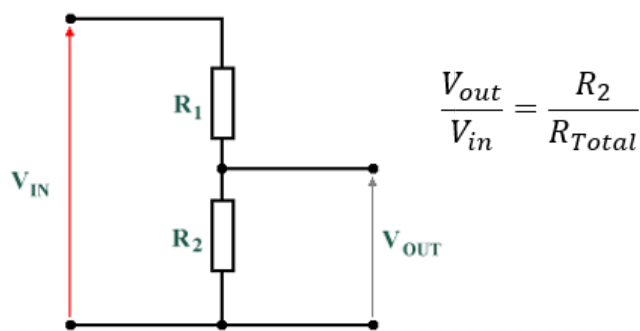

- Usage of a thermistor at R1:
  - Resistance decreases with increasing temperature.
  - Can be used in potential divider circuits to monitor and control temperatures.
- Usage of an LDR at R1:
  - Resistance decreases with increasing light intensity.
  - Can be used in potential divider circuits to monitor light intensity.

### 10.9. Potentiometers

- A potentiometer is a continuously variable potential divider used to compare potential differences
- Potential difference along the wire is proportional to the length of the wire
- Can be used to determine the unknown e.m.f. of a cell
- This can be done by moving the sliding contact along the wire until it finds the **null point** that the galvanometer shows a zero reading; the potentiometer is **balanced**

**Example:** E1 is 10 V, distance XY is equal to 1m. The potentiometer is balanced at point T which is 0.4m from X. Calculate E2

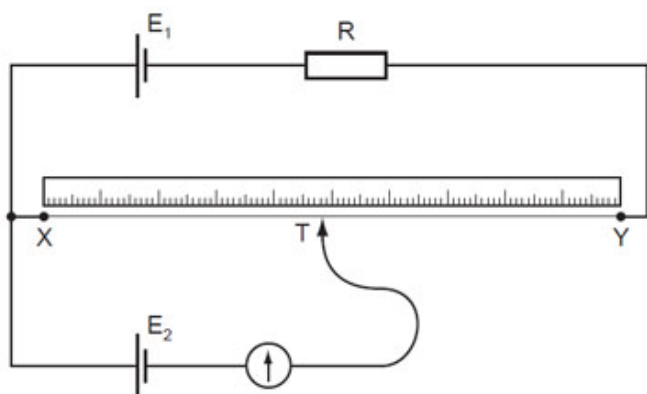

$$\frac{E_1}{E_2} = \frac{L_1}{L_2}$$

$$\frac{10}{E_2} = \frac{1}{0.4}$$

$$E_2 = 4V$$

## 11. Nuclear Physics

### 11.1. Geiger-Marsden $\alpha$

- Experiment: a beam of  $\alpha$ -particles is fired at thin gold foil

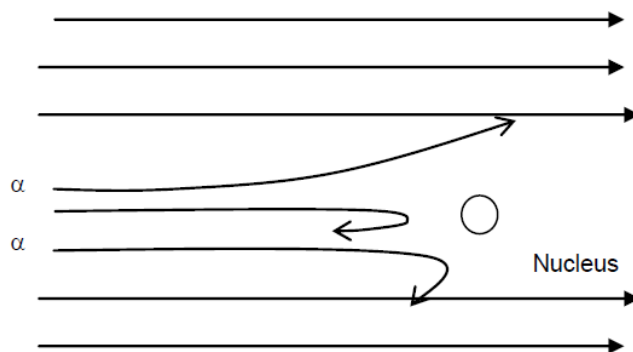
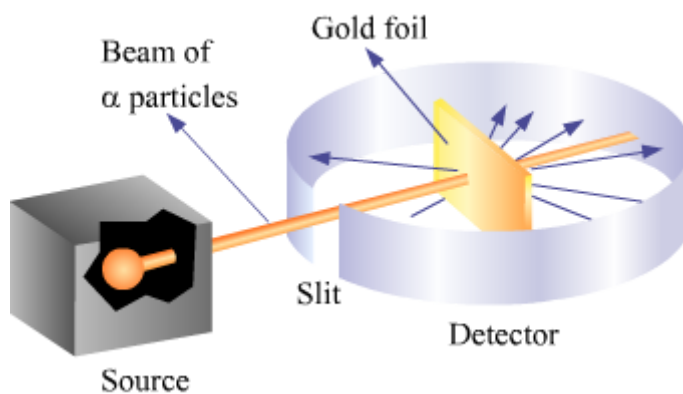

- Results of the experiment:
  - Most particles pass straight through
  - Some are scattered appreciably
  - Very few – 1 in 8,000 – suffered deflections > 90o
- Conclusion:
  - All mass and charge concentrated in the center of atom  $\therefore$  nucleus is small and very dense
  - Nucleus is positively charged as  $\alpha$ -particles are repelled/deflected

### 11.2. The Nuclear Atom

- **Nucleon number:** total number of protons and neutrons
- **Proton/atomic number:** total number of protons
- **Isotope:** atoms of the same element with a different number of neutrons but the same number of protons

### 11.3. Nuclear Processes

- During a nuclear process, nucleon number, proton number and mass-energy are conserved

Radioactive process are **random** and **spontaneous**

- **Random:** impossible to predict and each nucleus has the same probability of decaying per unit time
- **Spontaneous:** not affected by external factors such as the presence of other nuclei, temperature and pressure
- **Evidence on a graph:**
  - Random; graph will have fluctuations in count rate
  - Spontaneous; graph has same shape even at different temperatures, pressure etc.

### 11.4. Radiations

	$\alpha$ -particle	$\beta$ -particle	$\gamma$ -ray
$\beta^-$	$\beta^+$		
Identity	Helium nucleus	Fast-moving electron/positron	Electromagnetic
Symbol	${}^4_2\text{He}$	$-10e$	$+10e$
Charge	+2	-1	+1
Relative Mass	4	1/1840	0
Speed	Slow(106 ms <sup>-1</sup> )	Fast(108 ms <sup>-1</sup> )	V of Light(3 × 10 <sup>8</sup> ms <sup>-1</sup> )
Energy	Discrete	Varying	
Stopped by	Paper	Few mm of aluminum	Few cm of lead
Ionizing power	High	Low	Very Low
Effect of Magnetic	Deflected slightly	Deflected greater	Undeflected
Effect of Electric	Attracted to -ve	Attracted to	
	+ve	-ve	

### 11.5. Types of Decays

- $\alpha$  decay: loses a helium proton
- $\beta^-$  decay: neutron turns into a proton and an electron & electron antineutrino are emitted
- $\beta^+$  decay: proton turns into a neutron and a positron & electron neutrino are emitted
- $\gamma$  decay: a nucleus changes from a higher energy state to a lower energy state through the emission of electromagnetic radiation (photons)

### 11.6. Fundamental Particles

- Fundamental Particle:** a particle that cannot be split up into anything smaller
- Electron is a fundamental particle but protons and neutrons are not
- Protons and neutrons are made up of different combinations of smaller particles called quarks
- Table of Quarks:**

Quark	Symbol	Charge
Up	$u$	$+2/3+2/3$
Down	$d$	$-1/3-1/3$
Strange	$s$	$-1/3-1/3$

- Quark Models:**

Proton	Neutron

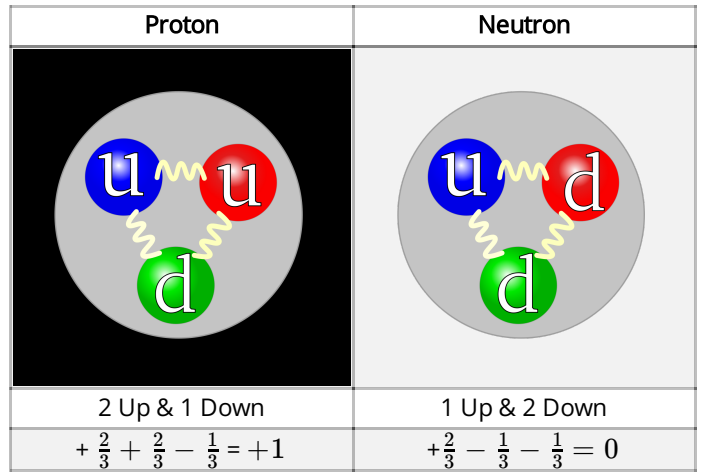

- All particles have their corresponding **antiparticle**
- A particle and its antiparticle are essentially the same except for their charge
- Table of Antiquarks:**

Antiquark	Symbol	Charge
Anti-Up	$\bar{u}$	-2/3
Anti-Down	$\bar{d}$	+1/3
Anti-Strange	$\bar{s}$	+1/3

- These antiquarks combine to similarly form respective antiprotons and antineutrons

### 11.7. Particle Families

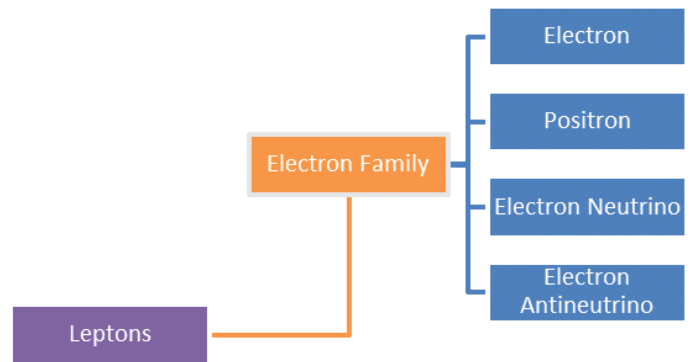

- There are other families under Leptons
- Leptons are a part of elementary particles



- There are other families under Hadrons too
- Hadrons are a part of composite particles



# CAIE AS LEVEL

## Physics (9702)

Copyright 2022 by ZNotes

These notes have been created by Bhavya Mavani for the 2022 syllabus

This website and its content is copyright of ZNotes Foundation - © ZNotes Foundation 2022. All rights reserved.

The document contains images and excerpts of text from educational resources available on the internet and printed books. If you are the owner of such media, text or visual, utilized in this document and do not accept its usage then we urge you to contact us and we would immediately replace said media.

No part of this document may be copied or re-uploaded to another website without the express, written permission of the copyright owner. Under no conditions may this document be distributed under the name of false author(s) or sold for financial gain; the document is solely meant for educational purposes and it is to remain a property available to all at no cost. It is current freely available from the website [www.znotes.org](http://www.znotes.org)

This work is licensed under a Creative Commons Attribution-NonCommercial-ShareAlike 4.0 International License.